



Operating Manual



Low Frequency Generator NF 16 2/3 Hz
Part Number 104702



CONTENTS

1	Introduction	1
2	Safety instructions	2
3	Technical data	2
4	Description	3
5	Transport and storage	3
6	Installation	3
6.1	General installation instructions	3
6.2	Installation of the LFG IP 20 - without S-1 or S-2	4
6.3	Installation of the LFG IP 20 - with S-1 or S-2	5
6.4	Electrical installation	5
7	Configuration	8
8	Commissioning and operation	8
8.1	LED display	8
8.2	ERROR display	8
8.3	Choke	9
9	Dismantling and disposal	9
-	EC/EU Declaration of Conformity	9

This operation manual must be kept at the place of work and be accessible to operators and maintenance personnel at all times.

Type	
Serial number	
Order number	

1. INTRODUCTION

The MAGNAFLUX low-frequency generator (LFG) is a durable device used for controlling demagnetising units from MAGNAFLUX GmbH .

To ensure safe and trouble-free operation of your LFG, you must read and observe these operating instructions, including the safety instructions included in them, before installation and commissioning.

We assume no liability for any customer-specific configuration, wiring and selection of operating elements.

The low frequency generator must only be used for the purposes specified in this operating manual.

If special device-specific instructions are listed on additional customer data sheets or on the LFG itself, these must be observed **before** the instructions in this manual.

NOTE:

This operating manual has been written for professionals who are authorised to install and commission electrical systems or systems with electromagnets. They must have the necessary specialist knowledge and be informed about the relevant accident prevention measures.

2. SAFETY INSTRUCTIONS

The LFG is safe to operate but it can be dangerous if not operated by trained personnel. The same applies to improper or unauthorised use.

- Installation and commissioning of the LFG must only be carried out by a trained electrician (as defined by VDE 1000, Part 10). Furthermore, the regulations of VDE 0100 standard must be followed.
- The LFG must be connected to a suitable power supply.
- The LFG may only be operated after the protective conductor connection has been installed and tested; only then is protection from dangerous shock currents ensured in accordance with DIN VDE 0100 Part 410. In ground-free systems, appropriate ground leakage protection must be provided in addition to the protective conductor.
- Risk of dangerous high voltage at the output terminals. There is no galvanic isolation to the mains input. Voltage is present at the output terminals even when the device is switched off. To avoid the risk of electric shocks, disconnect the LFG from the power supply and wait until the discharge time is over (i.e. when all displays have gone out) before clamping. In addition, all relevant regulations and standards for normal electric circuits (shock hazard protection, total insulation) also apply to the entire wiring of the magnetic circuit. Furthermore, protective earthing is required for the demagnetising unit, i.e., the housing must be connected to the protective conductor.
- The LFG must only be disconnected from the mains supply under the following conditions: (1) using a suitable disconnecting device, and (2) if the unit has been switched off via the control input. This applies to both the shut-off device and the protective device, when it is essential to observe the rated input current of the device.
- The connectors X2 and X3 are designed for easy replacing of the unit. They are designated “connectors without switching capacity” according to DIN EN61984. They must not be made live or put under load. As the connectors are not provided with locking screws, the operator must ensure that the connection cables are fitted with strain relief fixtures.

- The LFG must not be operated without protection. The relevant regulations based on the protection type of the housing must be observed. The standard housing complies with protection type IP 20. Failure to comply with the ambient conditions for the defined protection type incurs the risk of an electric shock and possible destruction of the unit.
- When operating a demagnetising unit with your LFG, make sure to follow all relevant accident prevention regulations and the operating instructions for the demagnetising unit.
- Repairs to the LFG may only be carried out by the manufacturer. Alterations are prohibited; any unauthorised modifications and changes are not permitted for safety reasons.

3. TECHNICAL DATA

Operating mode	Continuous operation
Input voltage	see type plate (230V AC $\pm 10\%$ or 400V AC $\pm 10\%$)
Mains frequency	50 / 60 Hz
Output current (for 50 Hz operation)	for demagnetizing unit: max.
Protection type	IP
Weight	kg
Air temperature during operation	0°C to 40°C
Air temperature in storage	-20°C to 60°C
Installation height	max. 1000 mNN*

* For operation at higher levels the output power will be reduced.

Connectable cable cross sections:

Control signal (X1)	0.25 to 2.5 mm ²
Mains connection (X2)	0.5 to 16 mm ²
Connection to demagnetising unit (X3)	0.5 to 16 mm ²

4. DESCRIPTION

The LFG is a control unit which was specifically developed for MAGNAFLUX demagnetising units. It is used as control gear for the demagnetising units, allowing operation with a frequency of 16.5 Hz. In many cases (depending on the parts being demagnetised), this results in significant improvements to the demagnetising results.

The LFG offers three modes of operation:

- Switching the demagnetising unit on and off with 50 Hz
- Switching the demagnetising unit on and off with 16.5 Hz
- Switching the demagnetising unit in ramps of 16.5 Hz

A 10-digit LED display shows the current demagnetising current. Over-current, heat-sink temperature and the 16.5 HZ function are monitored.

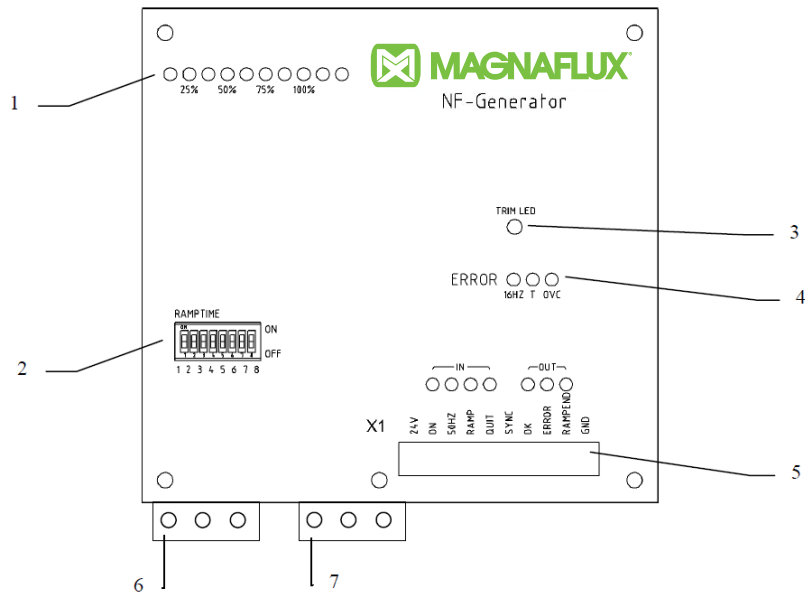

- | | |
|--|---|
| 1. LED display | 5. X1 control inputs and outputs |
| 2. Flip switches for setting ramp time | 6. X2 mains connection |
| 3. Fine adjustment LED display | 7. X3 Connection for demagnetising unit |
| 4. Error message | |

5. TRANSPORT AND STORAGE

The LFG devices are suitably packed at the MAGNAFLUX GmbH plant according to the agreed type of transport.

- Transport the device in its original packaging.
- Check for damages to the packaging or device.
- Store the unit in its original packaging in a dry and weather-protected area.
- Avoid any exposure to extreme heat and cold (see section 3 for permissible temperature range).

6. INSTALLATION

6.1 GENERAL INSTALLATION INSTRUCTIONS

The LFG generates heat during operation. The amount of heat generated depends on the output, and it must be dissipated. In general, **the ambient temperature must not exceed +40°C.**

The LFG is designed for vertical mounting in an electrical cabinet. To enable sufficient heat dissipation, the LFG unit must be installed with sufficient space between it and the cabinet walls, and any other equipment installed in the cabinet (see diagram on next page). Do not install the LFG above other devices with high heat dissipation.

If required, provide ventilation or install an air conditioner for the electrical cabinet. If fans are installed, it is essential to provide optimum cooling air supply.

The temperature must be checked during operation to ensure that the maximum permissible ambient temperature is not exceeded.

Make sure to keep the LFG unit clean as any contamination can lead to malfunctions or breakdowns.

6.2 INSTALLATION OF THE LFG IP 20 – WITHOUT S-1 OR S-2

Your LFG unit should be installed according to the instructions in this manual. The following options are available:

Option 1 – heat sink located outside the electrical cabinet

If your electrical cabinet is **not** large enough according to the requirements specified in this manual, the main power loss must be outside the cabinet.

The cabinet must be provided with an installation opening (see figure 2). Then the LFG must be installed with its housing **inside** the cabinet while the heat sink remains **outside** the cabinet (see figure 1).

Depending on the protection type of the electrical cabinet, a suitable seal (e.g. sealing compound, figure 2) must be provided between the heat sink and the cabinet wall.

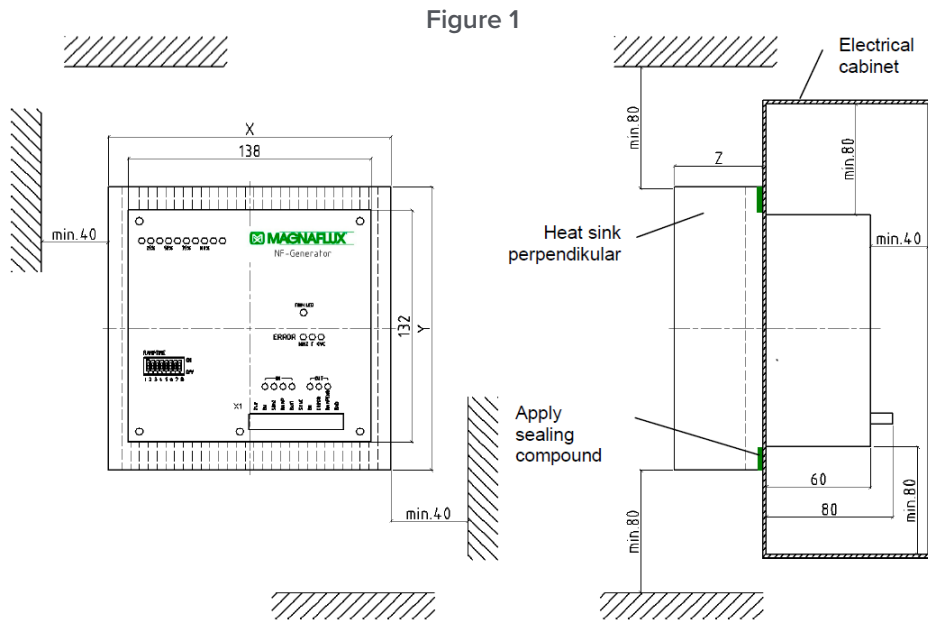

Heat sink for type	X	Y	Z	H	S
243-15/16,5	160 mm	160 mm	50 mm	120 mm	150 mm
243-30/16,5	200 mm	200 mm	84 mm	162.4 mm	150 mm

Figure 2: Panel cut-out in electrical cabinet for LFG

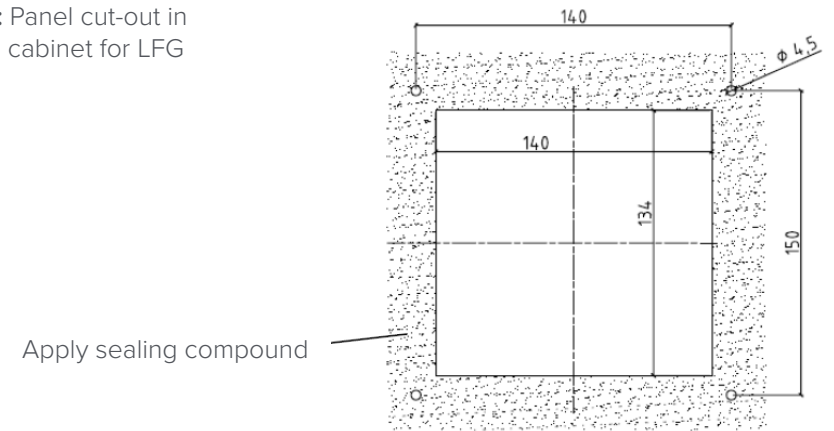

Option 2 – complete LFG inside the electrical cabinet

If your electrical cabinet is large enough according to the requirements specified in this manual, the complete LFG can be installed inside the cabinet.

To allow sufficient heat dissipation, the LFG must be installed at a sufficient distance from the cabinet walls or other devices. The following minimum distances must be maintained: vertical > 80 mm; horizontal > 40 mm (see figure 3).

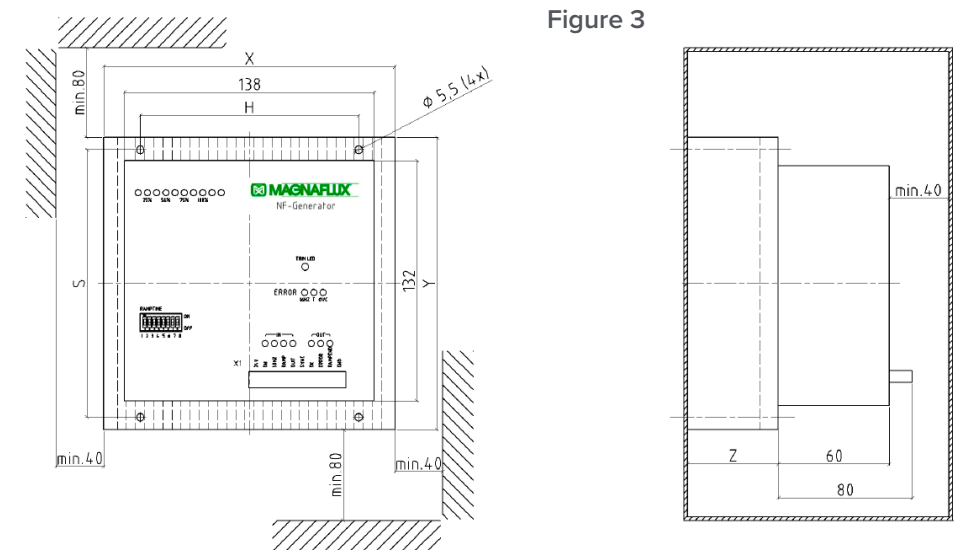

6.3 INSTALLATION OF THE LFG IP 20 – WITH S-1 OR S-2

The ready-to-use LFG type S-1 (for external control signals) or S-2 (with switch) is installed in the housing for wall installation. The mains choke to reduce any line interference is already included.

Installation dimensions ZK2-... (see technical data)

To allow sufficient heat dissipation, the heat must be installed at a sufficient distance from the LFG or other devices. The following minimum distances must be maintained: vertical > 80 mm; horizontal > 40 mm (see figure 3).

6.4 ELECTRICAL INSTALLATION

Overview of connections

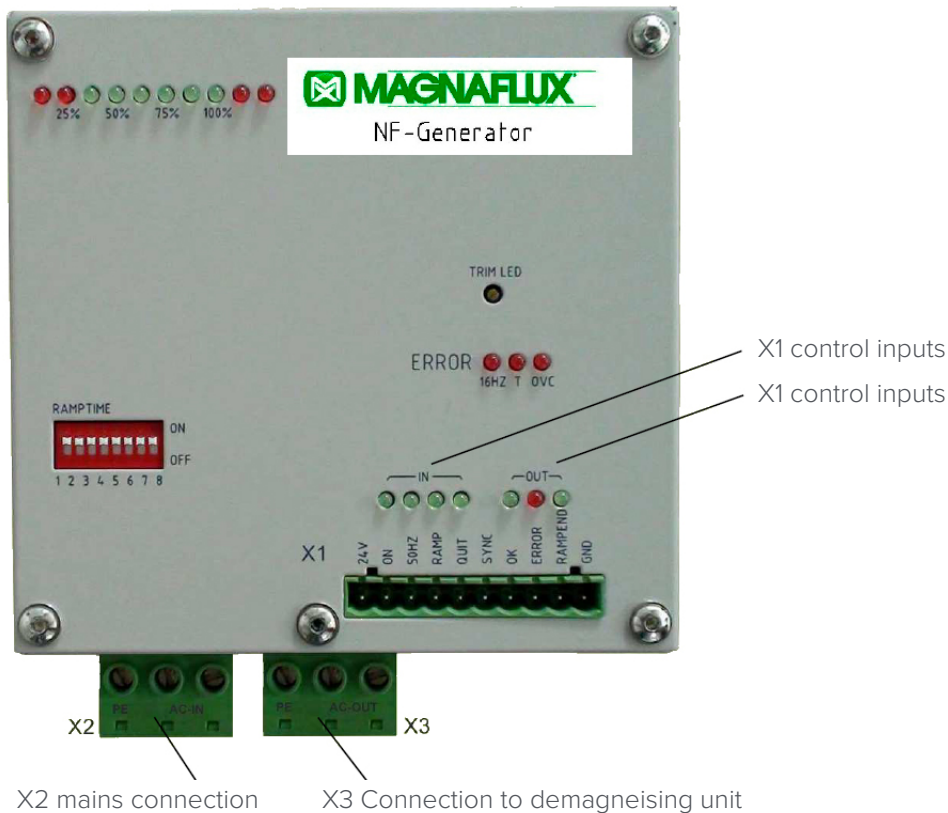

NOTE: The connectors X2 and X3 are designed for easy replacing of the unit. They are designated “connectors without switching capacity” according to DIN EN61984. They must not be made live or put under load. As the connectors are not provided with locking screws, the operator must ensure that the connection cables are fitted with strain relief fixtures.

Mains connection (X2)

The connection is made at a rated voltage of 230 V on the single-phase network between L1 and N or at a nominal voltage of 400 V at L1 and L2.

With regard to the electromagnetic compatibility, the use of a mains choke is necessary if no other interference suppression measures are fitted in the cabinet (for connection diagram, see section 9). For device types S-1 and S-2 the power choke to reduce line interference is already included.

Input voltage	See type plate (230V AC ±10% or 400V AC ±10%)
Mains frequency	50 / 60 Hz
Earth wire	The earth wire from the power supply to the LFG must have the same cross section as that of the demagnetising unit.
Power supply	The power supply must be designed in accordance with the performance data of the LFG.

The table on the next page shows an overview of our standard devices. Fusing of the devices is to be made according to the current input of the demagnetising unit (see table in page 6).

Connection of demagnetising unit (X3)

The demagnetising unit must be connected to a suitable cable cross-section at connector X3.

Connecting the control inputs and outputs (X1)

There are two variations to connect the control inputs (see circuit diagrams 1 and 2).

- Using the internal power supply. The LFG offers a floating 24V DC power supply for the control inputs.
- Using an external power supply. The potential-free control inputs of the LFG are controlled using an external power supply (24V DC).

Device type	Current input - Demagnetising unit *	System loss		Recommended pre-fusing	Power choke EMC		
		inside heat sink **	outside heat sink **		L _{Nom}	I _{Nom}	Part number
15/16.5	up to 10 A	36W	22W	gG 13 , Autom. C 13 A	2 x 3.9 mh	20 A	0216339
	up to 12.5 A	36W	22W	gG 16 A, Autom. C 16 A	2 x 3.9 mh	20 A	0216339
	up to 15 A	36W	22W	gG 20 A, Autom. C 20 A	2 x 3.9 mh	20 A	0216339
30/16.5	up to 17.5 A	62W	37W	gG 25 A, Autom. C 25 A	2 x 3.5 mh	50 a1.	0216340
	up to 24 A	62W	37W	gG 32 A, Autom. C 32 A	2 x 3.5 mh	50 a1.	0216340
	up to 30 A	62W	37W	gG 40 A, Autom. C 40 A	2 x 3.5 mh	50 a1.	0216340

* WARNING: the current input of the demagnetising unit is increased by about 30% in 16.5 Hz operation. ** corresponds to option 2; see chapter 6.2 *** corresponds to option 1; see chapter 6.2

Connection options for the control inputs and outputs

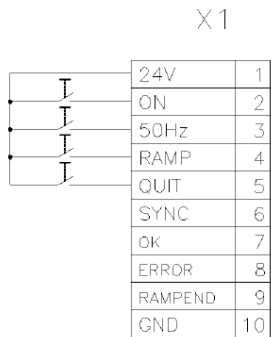

Circuit diagram 1

Inputs via internal power supply

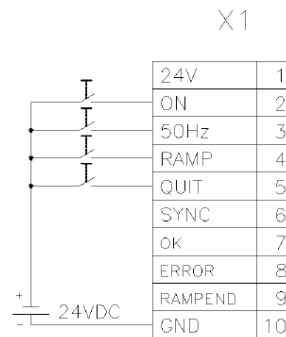

Circuit diagram 2

Inputs via external power supply

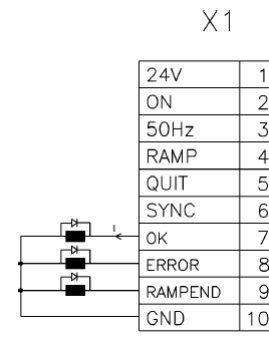

Circuit diagram 3

Connection of external coupling relay

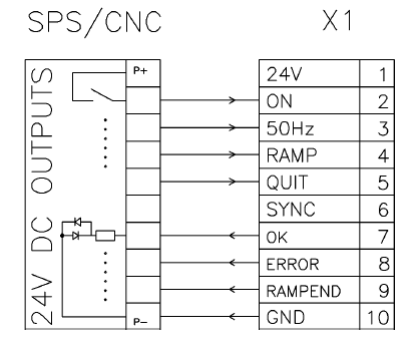

Circuit diagram 4

via PLC / CNC - inputs and outputs

Inputs

ON: 1 = On, 0 = Off

50HZ: 1 = 50Hz, 0 = 16.5Hz

RAMP: 1 = Ramp active (only 16.5 Hz), 0 = Ramp not active

QUIT: 1 → 0 acknowledge error

SYNC: Connection cable with master / slave configuration (see page 7.)

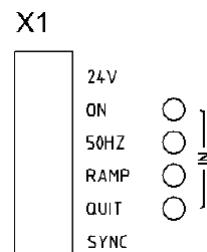

Definition of input statuses

Control voltage at input	Input current	Detected input signal
≤ 2V DC	0 mA	0
15V DC...30V DC	2. 4mA ... 8 mA	1
24V DC	4 mA ... 6 mA	1

Connecting the control outputs (X2)

CAUTION: Make sure no external voltage is applied to the 24V outputs of connector X2. This will damage the device.

Outputs

- SYNC:** Connection cable with master / slave configuration
- RAMPEND:** The ramp time has expired, current = 0
- OK:** Current within valid range, no error
- ERROR:** One of 3 possible errors is present (see chapter 8)

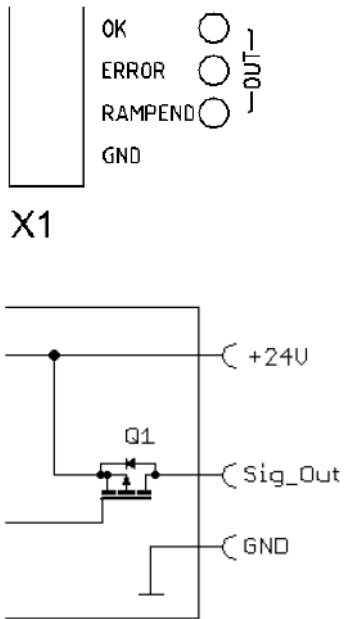

20 mA/output max.

Master/slave configuration

If the output of two demagnetising units exceeds the nominal output of the LFG, the output power can be doubled by synchronising two LFGs. To do this, follow the diagram below.

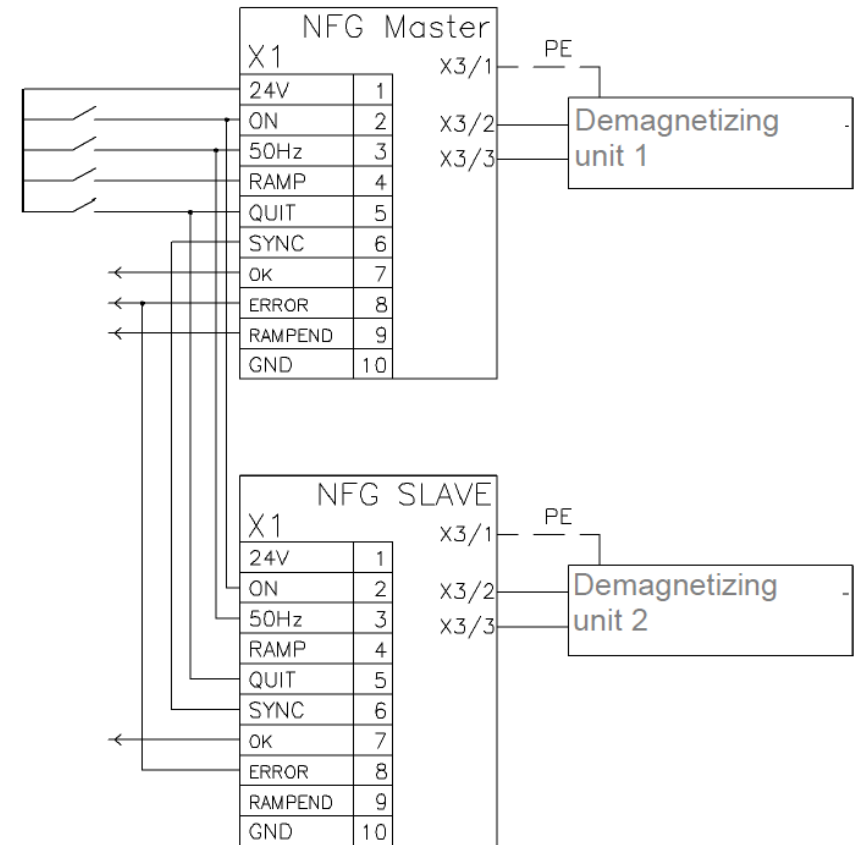

The output ERROR is OR linked, i.e. if an error occurs on a unit, the output is set to high potential.

Make sure to follow the operating instructions for the demagnetising unit (chapter 'Electrical connection'), tandem design (polarity).

7. CONFIGURATION

Make the following settings:

Set the LED display on the demagnetising unit

The setting must be made when the demagnetising unit is cold, and at 16.5 Hz. There must not be a workpiece on the demagnetising unit, otherwise the maximum current will not be reached.

Turn the screw of the potentiometer "TRIM LED" until the last green LED of the display lights up.

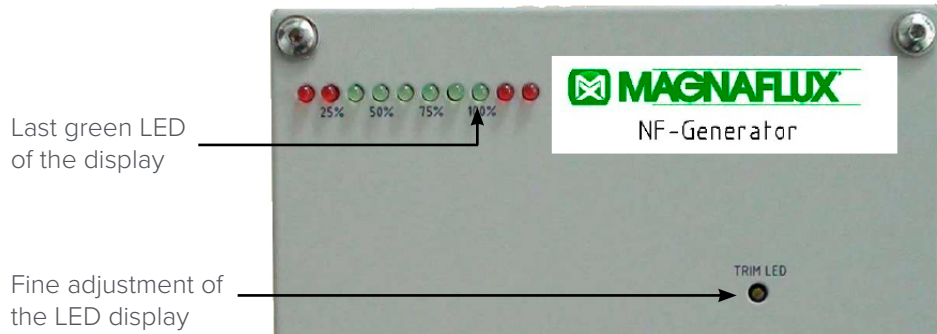

Set the ramp time

Use the flip switch to preset different ramp times.

1	2 sec
2	5 sec
3	10 sec
4	20 sec
5	40 sec
6	80 sec
7	120 sec
8	150 sec

1 sec. if all OFF

If several switches are selected, the values are added together.

NOTE: Due to component variations the ramp time may differ from the specified values in the table. The signal RAMP_END indicates when the ramp time has completely expired.

8. COMMISSIONING AND OPERATION



CAUTION: the electrical connection of the LFG must only be carried out by a qualified electrician. The electrician must be familiar with the relevant regulations for magnetic systems.

Before commissioning, the system must be fully installed. Perform a detailed functional test after installation, and after every change to the system or modification to the LFG.

8.1 LED DISPLAY



- The LED display can be used to check the current demagnetising current. Each LED corresponds to approx. 12.5% of the preset maximum value.
- **NOTE: the display is for function control only; it is not a measuring instrument.**
- If large parts are conveyed through the demagnetising area, the demagnetising current is reduced due to the increased inductivity.
- If 50 Hz operation is selected, the LED display is reduced by two LEDs or 25%.
- If a red LED lights up, check the cause.
- During ramp operation, the display may go out completely. In this mode, it is strongly recommended to reduce the demagnetising current to 0 (the OK signal is derived from the LED display and the ERROR signal / LED 3 to 9 and no error = 1).

8.2 ERROR DISPLAY

For all error conditions, the output "ERROR" is set (low active) and the device switches off.

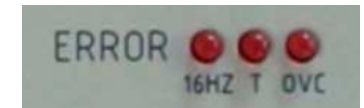

- 16Hz** This LED lights up when the power semiconductor switches incorrectly during 16.5 Hz operation (e.g. due to short-circuited thyristor)
- T** This LED lights up if the heat sink temperature reaches 75°C. If the heat sink temperature falls below 65°C, this LED goes out
- OVC** This LED lights up when the max. permissible current has been exceeded.

8.3 CHOKE

To reduce low-frequency system perturbations, the use of a mains choke is required.

LF-Generator

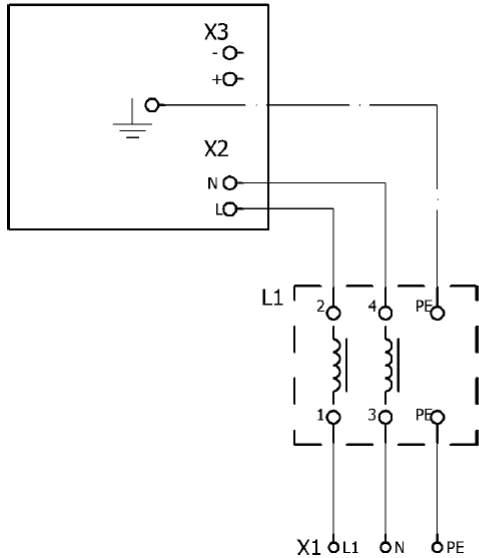

L1 Power choke

9. DISMANTLING AND DISPOSAL



DANGER: Before dismantling, disconnect the LFG from the power supply and secure it against reconnection. Wait 15 minutes after disconnection from mains supply to ensure that the components have fully discharged.

To dismantle the unit safely, follow the installation steps in reverse order. Make sure to follow all the safety instructions specified in this manual. These works must be carried out by qualified electricians only.

The LFG unit must be disposed of according to local regulations. The electrical components on the unit must NOT be disposed of in normal household waste. To ensure environmentally-friendly recycling and disposal of your old equipment, contact a certified electronic waste disposal service (disposal of industrial waste).

EC/EU DECLARATION OF CONFORMITY FOR MAGNAFLUX STANDARD EQUIPMENT



We hereby declare that this equipment complies with the following EU Directives. The device has been tested and approved. Any modification made to the device without our written consent will invalidate this declaration.

Applicable EC/EU Directives:

The Low Voltage Regulation (2014/35/EU)
Electromagnetic Compatibility (EMC) Directive 2014/108/EU

Equipment model: Low Frequency Generator

Equipment type: NF 16 2/3 Hz

Applied harmonised standards:

EN 60439-1, EN 61000-6-3, EN 61000-6-2

Authorised person for documentation:

Mr. Georg Koch, Quality Management Officer

Address:

Magnaflux GmbH, Stockertstr. 4-8, D-73457 Essingen, Germany

Person responsible:

Sales/Design Manager
Mr. Silvio Georgi

Signature:

Date: 01/01/2018



Stockertstraße 4-8, 73457 Essingen, Deutschland

Telephone: +49 (0) 7365 81-0

Email: sales.de@magnaflux.com

Web: www.magnaflux.eu/de

Faraday Road, South Dorcan Industrial Estate, Swindon, SN3 5HE, UK

Telephone: + 44 (0)1793 524566

Email: sales.eu@magnaflux.com

Web: www.magnaflux.eu