



# Operating Manual



Mobile Test Liquid Pump



## 1. CONSTRUCTION

The mobile test liquid pump is designed specifically for use in magnetic powder inspection. It is constructed primarily from the following components that are made from maintenance-free materials.

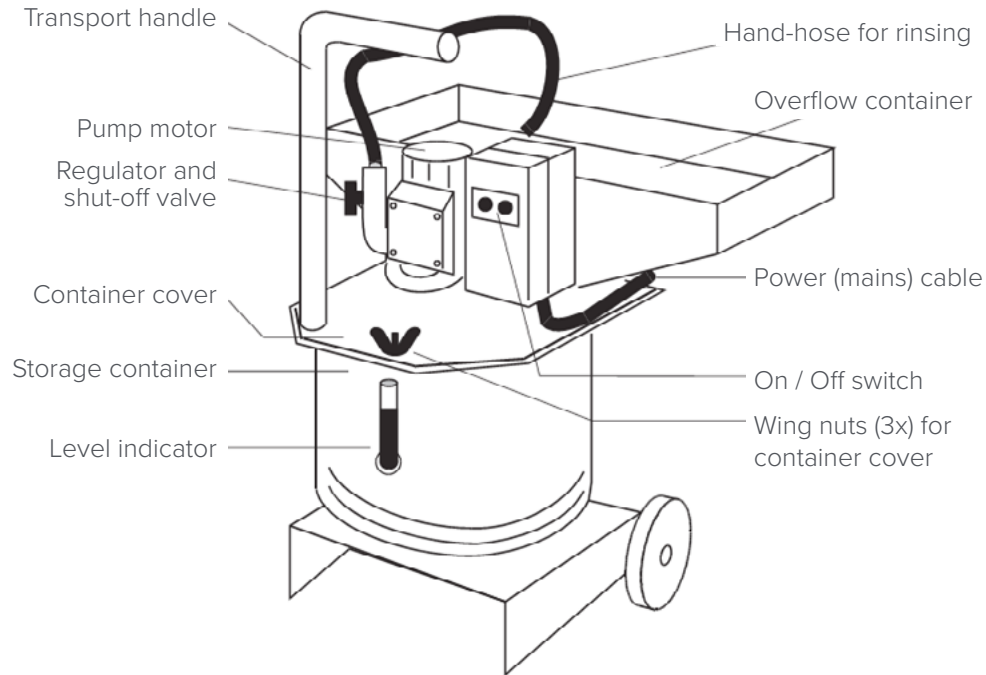

## 2. TECHNICAL SPECIFICATION

Container	
Material	Painted sheet steel
Overall dimensions (approx.)	H 650 mm, W 528 mm, D 530 mm
Hand-hose length	approx. 3 m
Overflow container dimensions	L 528 mm, W 260 mm, return opening 30 mm dia.
Container capacity	approx. 8 litres
Mains cable length	approx. 2.5 m
Mains voltage	3 x 400 V, 50 Hz AC, 0.15 kVA, 0.23A
Pump (with motor protection switch)	
Manufacturer	Brinkmann
Model	KTA40 / 220-07X
Power consumption	approx. 0.125 kW
Pump capacity	approx. 40 litres per minute
Protective systems	IP54

### 3. SAFETY INFORMATION

Read this manual carefully before using the machine. Keep for future use.

#### Intended use

The mobile test liquid pump is designed specifically for use in magnetic powder inspection. For safety reasons, any other use of this pump is prohibited. **Never** attach the upper half of the pump to, or manually submerge it in, any other container - the pump motor is sensitive to water and would pose an extreme shock hazard to the operator.

#### Electrical design

All electrical connections are made in compliance with VDE (German Electrical Standard) regulations. There is no danger to the operator when using the pump for its intended purpose.



#### DANGER OF ELECTROCUTION

In order to insure operator safety, repairs to the unit electrical parts must be carried out by trained personnel only.

**Never** operate the pump with a damaged power cable. Check the power cables for damage at regular intervals.

### 4. OPERATION

1. Fill the container with test liquid. Pay particular attention to the red maximum ~ mark on the level indicator.
2. Connect the unit to the mains supply (line voltage).
3. Turn on the pump by setting the switch to **I**.
4. Adjust the flow of the test liquid using the regulator valve.
5. Use the hand-hose to wash down your workpiece with test liquid (check the specific requirements of your magnetisation unit).
6. Turn off the pump by setting the switch to **O**.

## EC/EU DECLARATION OF CONFORMITY FOR MAGNAFLUX STANDARD EQUIPMENT



We hereby declare that this equipment complies with the following EU Directives. The device has been tested and approved. Any modification made to the device without our written consent will invalidate this declaration.

#### Applicable EC/EU Directives:

EC Regulation Machines, state 2006/42/EC appendix II A  
EU regulation Electromagnetic Compatibility, state 2014/30/EU

**Equipment model:** Mobile Test Liquid Tank

**Comm. number:** .....

**Serial number:** .....

#### Applied harmonised standards:

DIN EN ISO 12100:2011, DIN EN ISO 13849-1:2016, DIN EN ISO 13849-2:2013, DIN EN 60204-1:2014, DIN EN ISO 9934-3:2002

#### Other applicable standards and specifications:

VDE 0100-410:2007, VDE 0113-1:2014, BGV B11, ICNIRP

#### Authorised person for documentation:

Mr. Georg Koch, Quality Management Officer

#### Address:

Magnaflux GmbH, Stockertstr. 4-8, D-73457 Essingen, Germany

#### Person responsible:

Sales/Design Manager  
Mr. Silvio Georgi

#### Signature:

**Date:** 01/01/2018



Stockertstraße 4-8, 73457 Essingen, Deutschland

Telephone: +49 (0) 7365 81-0

Email: [sales.de@magnaflux.com](mailto:sales.de@magnaflux.com)

Web: [www.magnaflux.eu/de](http://www.magnaflux.eu/de)

Faraday Road, South Dorcan Industrial Estate, Swindon, SN3 5HE, UK

Telephone: + 44 (0)1793 524566

Email: [sales.eu@magnaflux.com](mailto:sales.eu@magnaflux.com)

Web: [www.magnaflux.eu](http://www.magnaflux.eu)